

Ph 3 - INTRODUCTORY PHYSICS LABORATORY

– California Institute of Technology –

Electrodynamic Ion Trapping

1 Introduction

Electrodynamic ion traps, also known as *Paul traps*, are often used to hold individual atomic or molecular ions in free space, and these traps are commonly used as starting points for physics experiments investigating atomic or molecular properties. Ion traps have been used for building rudimentary quantum computers as well, in which isolated ions serve as qubits that can be examined using probe lasers. Ion trapping techniques are also commonly used in chemical mass analyzers, for determining the molecular weights of complex compounds with high precision. Wolfgang Paul and Hans Dehmelt received the Nobel Prize for Physics in 1989 for developing ion traps, and this technology is still in widespread use today.

The overarching purpose of this experiment is for you to learn about ion traps and the physics underlying ion trapping, while picking up some useful laboratory skills. Trapping individual atoms is unfortunately quite difficult, requiring lots of time and expensive equipment. In the Ph 3 lab, therefore, you will be trapping and observing larger particles – about $25\ \mu\text{m}$ in diameter – as this is considerably easier while exploring the same physics. Also, you will soon discover that you can see $25\text{-}\mu\text{m}$ particles with your own eyes, and this adds some visual appeal to the exercise. In the lab you will be working with different types of ion trapping geometries, examining their characteristics, and making some measurements of individual trapped particles.

1.1 Earnshaw's Theorem

The basic idea of an ion trap is to confine a charged particle in free space using electric and/or magnetic fields. There is a famous theorem, called Earnshaw's theorem, stating that one cannot construct a stable ion trap using electrostatic fields alone. To trap a positively charged particle at some position in space, for example, the electric field vectors around that position would all have to be pointing inward. And Maxwell's equations, specifically Gauss's Law (which you will learn about in Ph1bc, if you have not already), tell us that this is impossible unless there is a net negative charge at that position. So, try as one might, it is not possible to create a static electric field geometry that will stably trap charged particles in free space.

There are magnetic variations of Earnshaw's theorem as well, for example stating that you cannot stably trap a simple bar magnet in free space using only static magnetic fields. Adding gravity does not help, and another version of Earnshaw's theorem states that you cannot levitate a stationary permanent magnet using only static magnetic fields.

Fortunately, there are many routes around Earnshaw's theorem. One popular engineering method is to use active feedback. For the magnetic case, one can continually measure the position of a levitated magnet and adjust the forces appropriately to keep the magnet positioned where you want it. This method is relatively cheap and easy to implement, and magnetically levitated trains work this way. Another way around Earnshaw's theorem for magnetic levitation is to use a spinning magnet instead of a stationary one. There is a toy called the *Levitron* (easily found online, if you are interested) that demonstrates levitation of a spinning magnet without using active feedback.

Paul and Dehmelt got around Earnshaw's theorem by using oscillating electric fields, since the theorem strictly applies only to static fields. It is not immediately obvious that you can use oscillating fields to trap particles (hence the Nobel Prize), so your first task in this lab is to understand the basic physics behind all this. The only real background you need is that the force on a charged particle is given by $\vec{F} = q\vec{E}$. The rest comes from a careful analysis of how particles behave in the presence of oscillating forces.

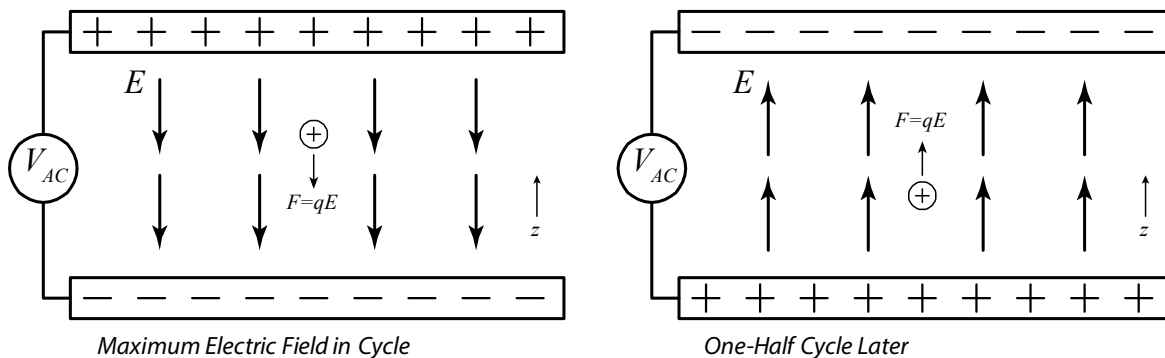

Figure 1. A charged particle placed initially at rest inside a parallel-plate capacitor. An oscillating voltage is applied to the capacitor, so the electric field oscillates with time. At any given time, however, the field is uniform between the plates. The oscillating electric field causes the particle position to oscillate. When the particle position z is high (left), the electric field pushes it down. When the particle z is low (right), the electric field pushes it back up. The average particle position $\langle z \rangle$ remains constant.

2 Basic Trap Dynamics

2.1 A Uniform Field Example

To begin, consider a charged particle placed inside an ideal parallel-plate capacitor, as shown schematically in Figure 1. Assume that the plates are large and separated by a distance d , and there is a vacuum between the plates. Then we can assume a uniform electric field in the space between the plates, at any time equal to $E(t) = V(t)/d$, where $V(t)$ is the applied voltage. Assume a sinusoidally oscillating voltage, $V(t) = V_0 \cos \omega t$, which gives an electric field between the plates $E(t) = E_0 \cos \omega t$, with $E_0 = V_0/d$. In this field we place a particle having a charge q , as shown in the Figure.

The time-dependent electric force on the particle is $F(t) = qE(t) = qE_0 \cos \omega t$, so the motion of the particle in the z direction is described by the equation of motion ($F = ma$)

$$m\ddot{z} = qE_0 \cos \omega t$$

To solve this equation, we try a solution of the form $z = A \cos \omega t$, giving

$$\begin{aligned} \dot{z} &= -\omega A \sin \omega t \\ \ddot{z} &= -\omega^2 A \cos \omega t \\ -m\omega^2 A \cos \omega t &= qE_0 \cos \omega t \\ \implies A &= -\frac{qE_0}{m\omega^2} \end{aligned}$$

and this gives the full solution

$$z(t) = z_{init} + v_{init}t - \frac{qE_0}{m\omega^2} \cos \omega t \quad (1)$$

where z_{init} is the initial position of the particle and v_{init} is its initial velocity. Note that this solution works in various trivial limits, for example if $q = 0$. (You can easily prove to yourself that Equation 1 satisfies the equation of motion – just plug the solution into the equation and see that it works. Proving that Equation 1 is the only possible solution is not so simple; *Uniqueness Theorems* doing just that are discussed at some length in Ma 2a.)

If we take $v_{init} = 0$, just to make life simpler, then the solution becomes

$$\begin{aligned} z(t) &= z_{init} - \frac{qE_0}{m\omega^2} \cos \omega t \\ &= z_{init} + \Delta z(t) \end{aligned} \quad (2)$$

In other words, the particle stays where we initially placed it (see Figure 1), but the oscillating electric field causes the particle position to oscillate. We will call $\Delta z(t)$ the particle *micromotion*, since we will typically assume this motion is fast and small. Motion over times much longer than $T = 1/\omega$ is often called the *secular* motion.

Note that the particle position is 180 degrees out of phase with the applied force: when Δz is positive, the force is negative, so the force pushes the particle back toward z_{init} . When Δz is negative, the force is positive, so again the force pushes the particle back toward z_{init} . This behavior is shown in Figure 1. So in this simple example the particle just oscillates about z_{init} . If you think about it for a minute, this all makes good sense.

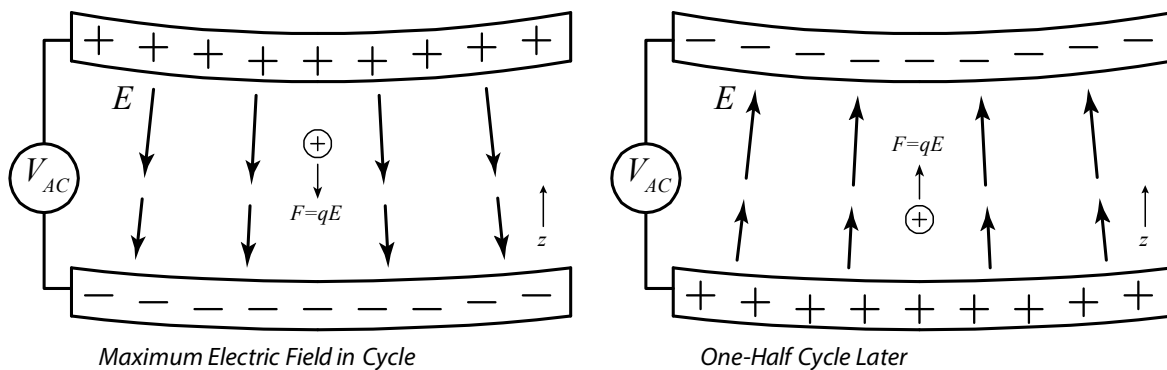

Figure 2. A charged particle placed initially at rest inside a curved-plate capacitor. The geometry of the plates causes a gradient in the electric field strength - the field is stronger for larger z (as shown by the longer arrows). The imbalance means that the electric force on the particle is stronger at the top of its motion (left) and weaker at the bottom (right). Averaging over time, there is a net force that pushes the particle down, toward the weaker-field region.

2.2 Add an Electric Field Gradient

Now we make the problem a bit more interesting by adding a field gradient, so the electric field is no longer uniform in space. One way to add an electric field gradient is to curve the plates of our capacitor, as shown in Figure 2. If we curve the plates a certain way (the details are not important here), then the electric field lines would look like those shown in Figure 2, and the field strength near the top plate will be higher than near the bottom plate (note the lengths of the field vectors in the Figure). Since we only curved the plates slightly, we haven't changed the field much, so the particle micromotion is about the same as it was before - the particle essentially just oscillates about its initial position.

But now we can see, just from the geometry in Figure 2, that the force over one cycle doesn't average to zero anymore. As shown in the Figure, when Δz is positive (left side of the figure), the particle experiences a stronger-than-average electric field pushing it downward. And when Δz is negative (right side of the figure), the upward force is weaker than average. This imbalance was not present in Figure 1. From this fairly basic reasoning, shown graphically in Figure 2, we deduce that there is a net force pushing the particle down. Put another way, the secular force, averaged over many oscillation cycles, pushes the particle toward a region where the oscillating electric field is weaker.

The math all supports this, as we can demonstrate. We write the modified field as

$$E(z, t) = (E_0 + E'z) \cos \omega t$$

where $E' = dE/dz$. We assume that E' is small, so the particle micromotion is not much different from $E' = 0$, the parallel-plate capacitor case. Here we also assume that we are initially placing the particle at $z_{init} = 0$, just to simplify the equations a bit.

With the added field gradient, the equation of motion becomes

$$m\ddot{z} = q(E_0 + E'z) \cos \omega t$$

Solving this exactly is nontrivial, but we can capture the essence of the physics by looking at the limit of low E' . Setting $E' = 0$ gives the micromotion we saw previously

$$z(t; E' = 0) = -\frac{qE_0}{m\omega^2} \cos \omega t$$

and for small E' we assume that the micromotion shouldn't change much. Then we use all this to calculate an average force on the particle as follows.

The total force on the particle at any given time is

$$F = q(E_0 + E'z) \cos \omega t$$

and we write the average force

$$\begin{aligned} \langle F \rangle &= \langle q(E_0 + E'z) \cos \omega t \rangle \\ &= \langle qE_0 \cos \omega t \rangle + \langle qE'z \cos \omega t \rangle \end{aligned}$$

where the average is over one oscillation cycle. Since E_0 is constant, we see that

$$\langle qE_0 \cos \omega t \rangle = qE_0 \langle \cos \omega t \rangle = 0$$

so

$$\langle F \rangle = \langle qE'z \cos \omega t \rangle$$

Into this we substitute in the $z(t; E' = 0)$ solution to give an approximate answer

$$\begin{aligned} \langle F \rangle &\approx \left\langle qE' \left(-\frac{qE_0}{m\omega^2} \cos \omega t \right) \cos \omega t \right\rangle \\ &\approx -\frac{q^2 E' E_0}{m\omega^2} \langle \cos^2 \omega t \rangle \end{aligned}$$

While this is certainly not an exact result, we can expect that it may be reasonably accurate in the limit of low E' . Since $\langle \sin^2 \omega t \rangle = \langle \cos^2 \omega t \rangle$, we can write $\langle \cos^2 \omega t \rangle = \frac{1}{2} \langle \sin^2 \omega t + \cos^2 \omega t \rangle = \frac{1}{2}$, so finally

$$\langle F \rangle \approx -\frac{q^2 E' E_0}{2m\omega^2} \quad (3)$$

The negative sign in this expression means that $\langle F \rangle$ pushes the particle toward a region of weaker electric fields. This turns out to be universally true (although we do not prove this here) – the time-averaged forces will always push particles toward regions of weaker oscillating electric fields. Note that $\langle F \rangle$ goes to zero when E' goes to zero, as we expect. Thus the math confirms our qualitative reasoning above, and it gives us a quantitative estimate for the secular force. Numerically integrating the equation of motion would give more accurate results, but Equation 3 is a good first step, and it is sufficient for the present discussion.

2.3 Quadrupole Traps

Now that we have a basic understanding of how particles behave in oscillating electric fields, we can proceed to make an ion trap by considering more complex field geometries. In particular, we will focus on what are called *quadrupole ion traps*, as shown in Figure 3. There are two varieties shown in this figure – 2D and 3D traps – but the underlying physics is similar for both.

To see how the 3D case works (the trap shown on the right-hand-side of Figure 3), consider the electric fields

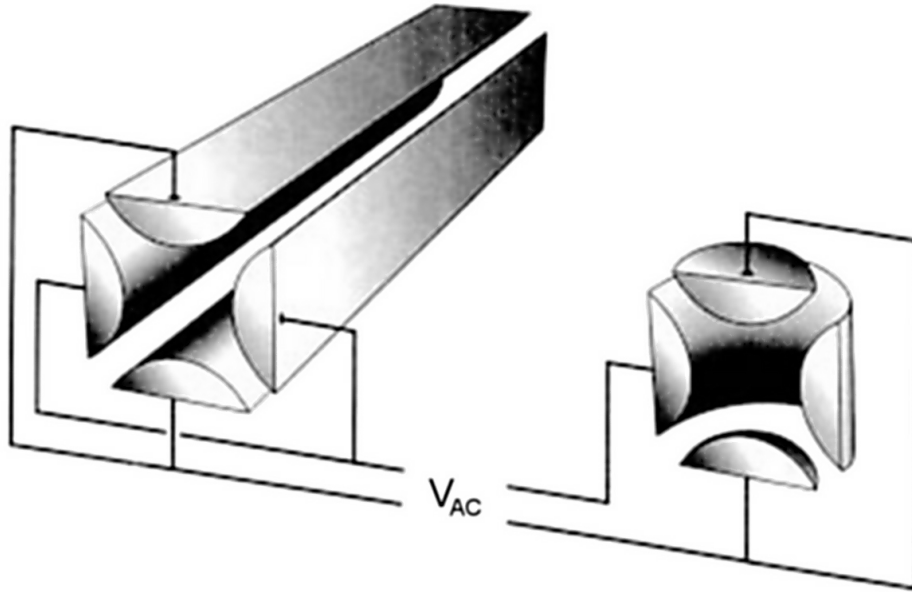

Figure 3. Two arrangements for making quadrupole electrodynamic ion traps. The electric fields in these traps are shown in subsequent figures. On the left you see a set of four electrodes making a 2-dimensional (2D) quadrupole trap. Particles are pushed toward the central axis of the trap, and there are no electric forces acting along the trap axis (except near the ends of the trap, where there are fringing fields). The diagram on the right shows a 3D quadrupole trap. The drawing shows a cut-away view – the actual trap has two roughly hemispherical end caps with a circular belt around the equator. (Image from <http://tera.chem.ut.ee/~jpenchuk/documents/kursused/Mass-spec/2.htm>)

produced in a couple simpler cases: two balls in a box, and a ring in a box, both shown in Figure 4. After taking Ph1, or perhaps even from high-school physics, you should have some intuition about the electric fields around charged objects, and hopefully the arrows in Figure 4 make some sense. It helps if you sketch for yourself the electric field around an isolated charged ball (just radial lines), and then sketch what happens when you bring two charged balls together. Note that the field vectors shown in Figure 4 represent snapshots of the oscillating fields. Multiply each vector in these plots by $\cos \omega t$ to see the fields at other times.

Actually calculating the fields in these cases is nontrivial, but the answer is fairly simple if we just look at the fields near the centers of both boxes. Around the center we can do what is essentially a Taylor series expansion of the vector fields (a bit more complicated than a Taylor expansion of a 1D function, but it's the same principle.) If we do this for the 3D case, then we find (given without proof here) that the electric potential can be approximated near the trap center ($r = z = 0$) as

$$V(r, z)_{3D-Quad} \approx A_0 - A_2 [2z^2 - r^2] \cos \omega t$$

where A_0 and A_2 are constants. The electric fields are then

$$\begin{aligned} E_z &\approx -\frac{\partial V}{\partial z} = 4A_2 z \cos \omega t \\ E_r &\approx -\frac{\partial V}{\partial r} = -2A_2 r \cos \omega t \end{aligned} \quad (4)$$

and Figure 5 shows a vector plot of the electric fields. Because this is a Taylor expansion, it applies for all the 3D quadrupole traps we have just discussed – the two-balls geometry, the ring geometry, and the more complicated geometry shown in the right-hand side of Figure 3. The approximation is only valid near the trap centers, but it works for any form of 3D quadrupole trap.

You should note several important characteristics of 3D quadrupole traps: 1) the electric field strength goes to zero at the origin, $r = z = 0$. We showed above that charged particles are pushed toward regions of lower field

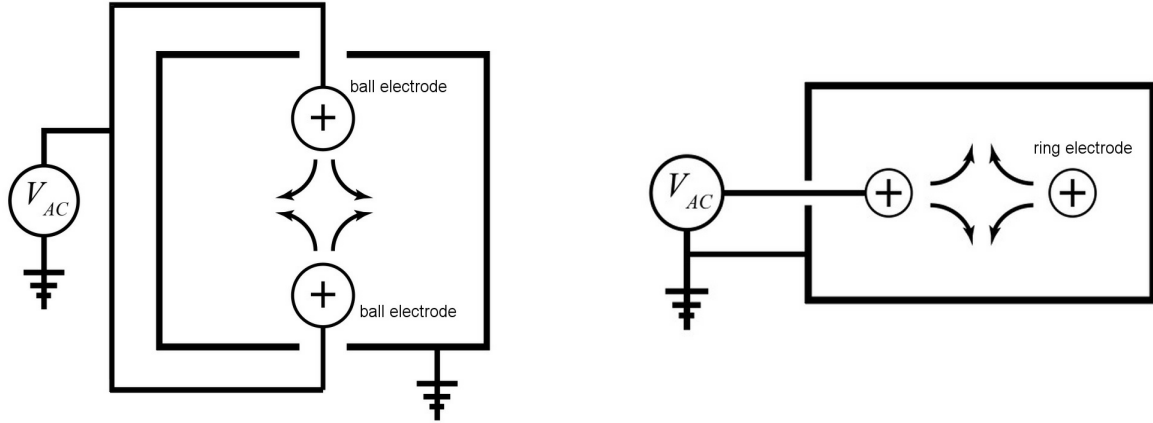

Figure 4. Left: Two ball electrodes in a grounded box, connected to a sinusoidal (AC) voltage source as shown. The arrows roughly show the electric fields between the balls, at a point in the cycle when the voltage on the balls is positive. Right: A ring electrode in a grounded box, here showing the ring in cross-section. Again the arrows roughly show the electric fields near the center of the ring. Note that, from symmetry, the electric field at the center of both boxes is zero.

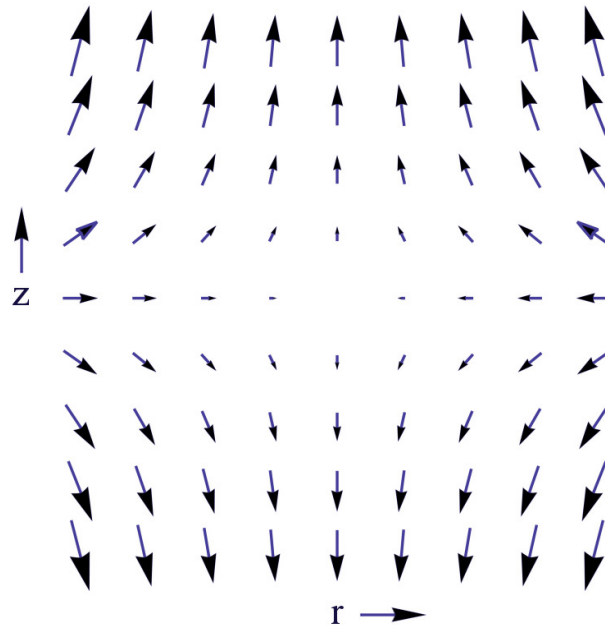

Figure 5. A snapshot of the electric field geometry near the center of a 3D quadrupole trap, as a function of radius r and height z . The length of each vector is proportional to the electric field at its midpoint. Multiply each vector by $\cos(\omega t)$ to obtain the electric fields at other times.

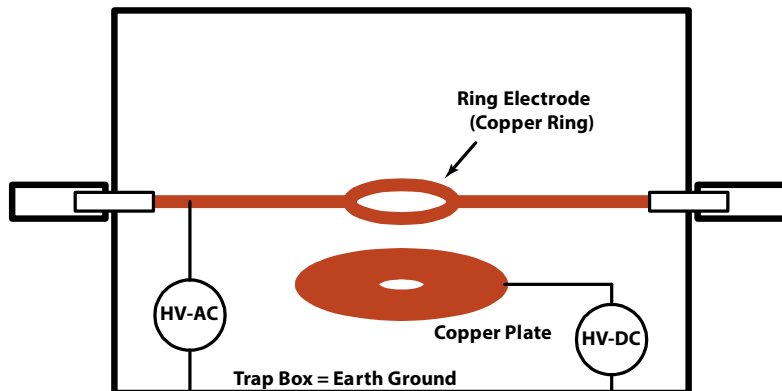

Figure 6. A schematic diagram of the Ring Trap Box. The copper ring electrode is like the "belt" electrode shown in the 3D trap in Figure 3. The endcap electrodes have essentially been replaced by the rest of the box, which is grounded. The ring+box still produces a 3D quadrupole field near the trap center. The lower copper plate is used for applying a static (DC) electric field to help support the particles against gravity. The HV-AC and HV-DC circles in the diagram correspond to knobs on the control chassis.

strengths, so therefore charged particles are pushed toward the origin; 2) the electric field strengths increase linearly with distance away from the trap center. Thus, for example, dE_z/dz is a constant along the z axis in a 3D trap.

At this point it is beneficial to pause, take a breath, stare at the electric field plots for a while, and ponder what is going on inside these traps. At the trap center, there are no electric fields, so no electric forces at all. A particle at the trap center, with no velocity, would just sit there. Away from the trap center, the electric fields are nonzero, so a charged particle experiences what we are calling the micromotion – it oscillates back and forth, in our case at 60 Hz. Averaging over a few cycles, there is also a weaker secular force that pushes the particles toward the origin. All around the origin, in any direction, the particles are pushed toward the origin; thus we have a trap.

Key in this discussion is to separate in your head the micromotion from the secular motion. The micromotion exists whenever the oscillating fields are nonzero. But you can average over the micromotion and extract the average secular force $\langle F \rangle$, as we did above. All the stationary forces, such as gravity, combine with $\langle F \rangle$ to determine the long-term behavior of the particle. So the short-term micromotion and the long-term secular motion can be dealt with separately, both in the math and in one's thinking about the overall trap dynamics.

3 Lab Procedures – Week One

Your main objectives for the first lab session are to examine the ion traps under various conditions and gain a qualitative understanding of how they work. What follows are some step-by-step instructions on how to set up the ion traps. Each paragraph has a small task, and in series they will guide you through the lab.

3.1 The Ring Trap

- Begin by locating the Ring Trap, which is one of three small black *Trap Boxes* on the lab bench. All three plug into the blue electronics chassis. The Ring Trap Box is the one with a glass prism on top. If this Trap Box is already plugged into the chassis, you can leave it there. Otherwise make sure the Power switch is off, remove whatever Trap Box is installed, and plug in the Ring Trap. You may want to ask your TA for help with this step.
- Once the Ring Trap Box is in place, turn the HV-AC Adjust knob to zero and then turn on the Power switch. You

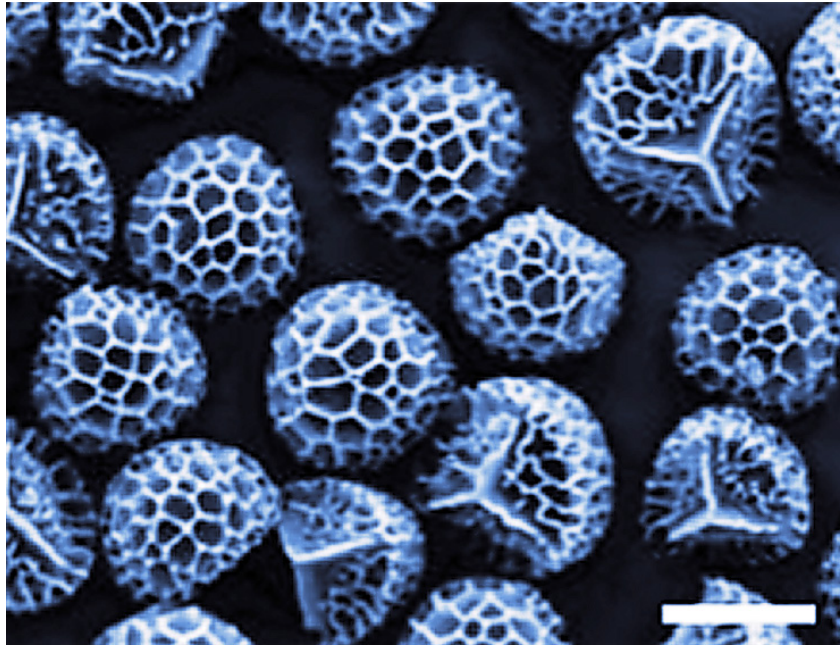

Figure 7. A high-resolution electron micrograph of some *Lycopodium* club moss spores, with a scale bar of $25\ \mu\text{m}$. The average material density in the spores was measured to be $510 \pm 40\ \text{kg/m}^3$, about half the density of water. [The electron microscope image is from "Naturally occurring spore particles at planar fluid interfaces and in emulsions", B.P. Binks, J.H. Clint, G. Mackenzie, C. Simcock and C.P. Whitby, *Langmuir*, 21, 8161-8167 (2005).]

should see a red light on top of the chassis, and a green laser beam. Make sure the laser is pointing in a horizontal direction, and then raise the laser post and steer the laser into the side of the prism. Again, ask you TA for help if needed. If the laser is aligned correctly, you should see a broad laser spot, about 10 mm in diameter, hitting the bottom of the Trap Box. If the laser is aligned well, the beam will be centered on a 6mm-diameter hole at the bottom of the box.

- The overall layout of the Ring Trap is shown in Figure 6. If you look inside the Trap Box, you will easily see the copper ring, about 20 mm in diameter. The ring is soldered to horizontal bars, and these connect to handles outside the Trap Box. Turn the handles and see that the ring rotates. You can also see the wire connection to the ring on left side of the ring.
- The Trap Box itself is grounded (at zero electrical potential relative to the earth), while a large oscillatory voltage, up to $\text{HV-AC} = 6000$ volts, can be applied to the ring. The electric fields around the ring and the horizontal bars have some complicated geometry, but the fields inside the ring are simpler. If you think about, you will see that the fields near the ring center are like the 3D quadrupole electric fields described above.
- The next step is to place some particles in the Ring Trap, and for this purpose you should find a small beaker of *Lycopodium* Club Moss spores on the lab bench. These are spores, commonly found in Nature (there are about 1000 species of *Lycopodium* mosses). They are basically harmless dust particles, but if you have serious problems with asthma or pollen allergies, these particles may aggravate your symptoms if you put a lot into the air. There is always dust in the air, so most people are not bothered by these particles. If you find these particles are bothering you, we can provide a particle mask for you to wear in the lab. Since these particles are fairly harmless, you should be able to eat or breathe in the particles without serious side-effects (although neither practice is recommended!). The *Lycopodium* spores are fairly uniform in size and fairly spherical in shape, with diameters around 25 microns.
- A quick safety note. While you will be working with high voltages in this lab, all electric currents are limited to less than 1 mA. At such low currents, you might get a small shock (similar to a static electricity shock), but it is not dangerous. Also, you are unlikely to experience any shocks at all (other than static shocks that come from rubbing your shoes on the carpet), since the high-voltage components are all tucked inside the Trap Boxes.

- With the Power switch on, turn up the HV-AC Adjust knob (HV-AC = High Voltage, Alternating Current) to about 4 kV, which applies 4000 volts to the copper ring, oscillating at 60 Hz. Turn the HV-DC Adjust to about halfway (using the Coarse knob). To be on the safe side, *you should not touch the ring, either directly with your fingers, or with any metal objects, when the high voltage is on.* It is okay to touch the trap handles (which are highly insulated), and it is okay to touch the Trap Box (which is grounded). Also, turn the power off before removing any Trap Box.
- Find the Teflon wand on the lab bench, and charge it up by rubbing it on some fabric. You can use the cloth provided on the lab bench for this, or you could also just use whatever you are wearing (you may get a few spores on your clothes). Just charge up the tip (very little rubbing is needed for this), then dip the tip into the beaker of spores, and you should see a small clump of yellow spores sticking to the wand.
- With the plane of the ring oriented horizontally, insert the wand into the Trap Box through the opening on the top of the box. It is okay to touch the ring with the plastic wand, since it is nonconducting, but just bringing the wand near the ring should be sufficient. Hold the tip of the wand over the ring and tap the wand gently. Some charged spores should fall from the wand into the ring and be trapped. You can see this best by looking through the either opening in the box while bringing the wand in. The spore particles are small, but they are illuminated by the laser, so they should be easily visible inside the ring. Just about any air currents will blow the particles out of the trap, however, so hold your breath when your face is near the Trap Box. If you do not see trapped particles right away, try loading the wand again and drop particles into the ring from above. If still nothing, ask your TA for assistance. It is not necessary to pour large amounts of dust into the Trap Boxes, so please don't do that. It makes a dusty mess.
- Once you get the hang of it, you should be able to load many dozens of particles into the trap with ease. Once you have a few particles trapped, you can add more by bringing a loaded wand in from the top, holding it over the ring, and tapping it gently to drop particles into the trap. For the most particles, turn the AC voltage all the way up.
- If your eyesight is pretty good, then you should see that the trapped particles look like short bits of bright green hair. This is the 60-Hz micromotion you are seeing. Each streak of light is one particle oscillating along the electric field lines. The charged particles also repel each other, so they tend to form what is called a *Coulomb crystal*. If everything was simple, stationary, and uniform, the particles would form a simple lattice structure. But the electric fields in the ring trap are somewhat complex, so the Coulomb crystal is not a simple lattice. Nevertheless you can see that the particles spread out to form a somewhat uniform distribution, with something like a lattice structure. In some instances the particles like to situate themselves on more of a spherical shell, since they want to get as far from one another as they can. You may want to tweak the laser pointing so the beam is centered on the cloud of trapped particles, and you can do this at any time.
- Feel free to rotate the ring while particles are trapped, and change the HV-AC amplitude as well. You should see that when the AC voltage is very high, the trap is smaller and the motion is more frenetic. You can see this especially well when the ring plane is near vertical. When you turn down the HV-AC, the trapping is weaker and gravity pulls particles out of the trap.
- Next increase the HV-DC Adjust while watching some trapped particles. This applies a static negative voltage to the copper plate (see Figure 6) below the ring. If the trapped particles are negatively charged (as they should be at this point), then the DC voltage will push up on the particles, raising the cloud of trapped particles. This is best seen from the side, though the opening in the front of the Trap Box. (Note the naming conventions: DC = Direct Current, which in this case means a static voltage and static electric fields. AC = Alternating Current, which in this case means voltages and electric fields that oscillate at 60 Hz. Note also that you can apply both AC and DC voltages at the same time.)
- Next charge up the Teflon wand by rubbing the tip as usual, but this time do not load it with particles. If you bring the wand near the trapped particles, you can see how they react. Better still, bring the wand in from underneath the trap, and see how it lifts the cloud up, much like the DC voltage did. This happens because the Teflon wand picks up a negative charge when you rub it, and the negative charge repels the negatively charged particles. Similarly the DC voltage puts a negative charge on the copper plate. Both lift the cloud by applying a static electric field. If that doesn't make sense, ask your TA.

Table 1. The Triboelectric Series

Most Positive (+)	
Air	
Human Hands, Skin	
Asbestos	
Rabbit Fur	+++
Glass	
Human Hair	
Mica	
Nylon	
Wool	
Lead	
Cat Fur	+
Silk	
Aluminum	
Paper	
Cotton	
Steel	
Wood	
Lucite	
Sealing Wax	-
Amber	
Rubber Balloon	
Hard Rubber	
Mylar	
Nickel	
Copper	
Silver	
uv Resist	
Brass	
Synthetic Rubber	
Gold, Platinum	
Sulfur	
Acetate, Rayon	
Polyester	
Celluloid	
Polystyrene	
Orlon, Acrylic	
Cellophane Tape	
Polyvinylidene chloride (Saran)	
Polyurethane	
Polyethylene	
Polypropylene	
Polyvinylchloride (Vinyl)	
Kel-F (PCTFE)	---
Silicon	
Teflon	
Silicone Rubber	
Most Negative (-)	

Figure 8. The Triboelectric Series, which is something of a qualitative ranking of materials by how they charge up from friction. When two materials are rubbed together, the positive materials (at the top of the list) tend to become positively charged, while the negative materials (at the bottom of the list) tend to become negatively charged. Your two wands are made from teflon and nylon. (Image source http://www.siliconfareast.com/tribo_series.htm)

- This is a good time to pause for a moment and look at the *Triboelectric Series*, shown in Figure 8. The Triboelectric Series is a somewhat qualitative ranking of materials, where the rank depends on how the material charges when it is rubbed with other materials. If you look at Figure 8, you will see that Teflon is strongly negative on this list, which means Teflon picks up a negative charge when you rub it with just about anything else. The negatively charged wand attracts the spore particles, and they acquire some negative charge when they fly off the wand and into the trap. Thus you have negatively charged spores from a negatively charged wand.
- How all this charging works in detail is complicated and not well understood. For nonconducting materials like Teflon, the charge they pick up tends to sit on the surface and it does not quickly dissipate. Although triboelectricity is not well understood, it is nevertheless widely used in applications. Photocopiers and laser printers all rely heavily on the use of triboelectric drums to hold toner particles, for example. Triboelectricity is one of those things that is widely used in engineering, but the physics is so messy that we don't like to talk about it much. We will not dwell much on it here either, but you should at least know about the Triboelectric Series.
- The next step is to get a better view of the trapped particles using a low-power microscope (in this case a macro lens) attached to a camera. If the camera is not mounted behind the Trap Box, ask your TA for help moving it. Then turn on the television (using the remote) and turn on the camera (using the switch on top of the camera). When both are on, you should see the copper ring nearly filling the field of view on the TV. If you trap some particles, you can see those also.
- You will immediately see a lot of background light in the image, coming through the front opening in the Trap Box. After placing some particles in the trap, cover the front opening with one of the black plastic covers. Best to slide it in slowly from the side, to avoid air currents that blow particles out of the trap. Cover the top opening with the smaller plastic cover. Once these covers are in place, the background should be much darker, and you will find that the trap is much less perturbed by outside movements.
- Set the shutter speed to 1/10 second (using a wheel on the back of the camera; inconvenient, but that's where it is). You can see the setting on the bottom left of the television screen. You can adjust the lens aperture (also called the *f/stop*) using a ring on the lens. Adjust this ring so the image is not too bright, not too dark. You are welcome to play with these settings if you wish, as tweaking the setting can give you a better picture. Focusing is done by moving the camera back and forth on the mounting rail, not by adjusting the lens (this is typically how one focuses microscopes). If you need help getting a good image, ask your TA for assistance.
- With the TV working, you can start documenting at least some of your observations in your lab notebook, and you can add photographs of the trapped particles. The easiest way to take photographs is to use your smartphone to photograph the TV screen. If you don't have a smartphone, we have an ipod in the lab you can use. In both cases you can e-mail the photos to yourself and print them out later, or use the computer in the lab. Using the attached camera directly gives somewhat better pictures (not a lot better, it turns out), but they are stored on a memory card, which makes extracting the photos more of a hassle.
- You can also find Nylon on the Triboelectric Series in Figure 8, and you see that this material has a fairly positive ranking in the table. So try charging the Nylon wand (rubbing with the same cloth does the trick) and use it to load some particles into the trap. This time you should find that the HV-DC voltage pulls the particles down, indicating that they are positively charged.
- Next use the Teflon wand (as it generally works better than the Nylon wand) to load a good number of particles into the trap, and then put the air-shield covers back in place. Turn the ring so it is nearly horizontal, and you can see how the micromotion of the particles traces out the vector electric fields. Turn the HV-AC down, and you will see particles leak out the bottom of the trap. You can stop this leaking to some extent using the HV-DC. View the trap with the ring plane nearly vertical as well, and see what happens as you adjust the HV-AC and HV-DC. Repeat all this as often as you want, and take some photos with large clouds of ions, both with the ring plane horizontal and vertical.
- Next you can observe the particle micromotion more clearly by strobing the laser. To do this, first connect the Strobe Monitor to an oscilloscope. The T-off knob on the trapping chassis adjusts the time that the Strobe Monitor signal is low, as you can see on the oscilloscope. Similarly the T-on knob changes the time the pulse is high. Set T-on to its maximum, then use the "measure" feature on the oscilloscope to measure the frequency of the strobe signal. With this running, adjust T-off so the pulse frequency is close to 61 Hz.

- Once you have a good signal on the oscilloscope, load the trap with the ring plane near vertical, so you see a large and fairly stable cloud of particles. Use the air-shield covers as needed. Then connect the Strobe OUT (which is the same signal you are viewing on the oscilloscope) to the Laser Strobe IN. When this connection is made, the laser will be on when the pulsed signal is high, off when the pulse signal is low.
- If the TV picture goes dark, that is because the laser is not on all the time, so there is less illumination overall. Counter this by increasing the shutter speed to $\frac{1}{4}$ second, and then open up the lens aperture. You may have to refocus also, by moving the camera back and forth. If all goes well, you should see the cloud of particles oscillating in and out at about one Hz. If you adjust the frequency to exactly match the trapping frequency, then the motion will be “stopped” by the strobing of the laser. The T-on knob is a good way to tweak the frequency, but use the oscilloscope to monitor the signal. Set the ring plane horizontal and observe the micromotion in this configuration also. Reload the trap as needed.
- As a final exercise using the Ring Trap, stop strobing the laser and load a small number of particles into the trap with HV-AC at 2 kV. Quickly lower and raise the fields to knock some particles out of the trap, until only one remains. This may take several attempts, but you should be able to achieve a single trapped particle.
- With the ring plane near vertical, observe how the DC fields affect the particle. With the DC fields off, gravity pulls down on the particle, so it must be displaced from the center of the trap. (Why? Because at the center of the ring, the electric fields go to zero, and thus the trap exerts no force there. So the particle is pulled downward until the trapping forces balance gravity.) Thus with HV-DC turned off, the particle is below the trap center, and it experiences some micromotion.
- As you turn up HV-DC, you can reach a point where the DC electric force just balances gravity. When this happens, the particle goes to the center of the trap, and the micromotion goes to zero. (It may not be exactly zero, owing to small stray electric fields.) If you turn HV-DC up further, then the DC field forces are stronger than gravity, so again the particle cannot come to rest at the trap center. If none of this happens, try another particle. If it still isn't making sense, ask your TA for assistance. Take a photo of the trap with a single trapped particle with zero (or close to it) micromotion.

3.2 The Linear Trap

The next step in the lab is to move on to the Linear Trap, which is shown schematically in Figure 9.

- Turn off the Power switch, remove the Ring Trap Box, and replace it with the Linear Trap Box. You may want to ask your TA for assistance doing this. If you look inside the front opening, you can see the four trap bars and two Teflon end caps. Note also the top and bottom copper plates, as in the diagram in Figure 9. A flashlight gives a better view of these components. Use one of the trap wands to push the Teflon end caps to the ends of the trap (i.e., one end cap should be at each end, as shown in Figure 9). Lower the laser post so the laser beam shines in one end of the Trap Box and out the other end. You should see some laser light coming out the exit hole.
- Loading particles is pretty much the same as with the Ring Trap. Use the Teflon wand for best results. You can view the particles either directly through the front opening or via the camera. Again the trapped particles are easily pushed around by air currents, so you may want to use the air shields once you have loaded some particles. Again it is useful to tweak the laser pointing to maximize the brightness of the particles. The picture is a bit better focused if you reduce the lens aperture as well. You might see some reflections above and below the particles, coming from the shiny copper bars.
- Remember there is little trapping along the trap axis, so the particles move quite freely in the horizontal direction. Air currents push them around easily along this axis, for example. Because Teflon is so electronegative, the end caps tend to become negatively charged, so these act to keep the negatively charged particles from leaking out the ends. If you try loading positively charged particles using the Nylon wand, you will find that they are attracted to the negative end caps, so these particles more readily leak out the ends. (Try it.)
- If you adjust HV-DC, you will see the particles are pushed up by the static field, as they were with the Ring Trap. The particles all have somewhat different charges and masses, so they behave differently as a result. If you load a few dozen particles and adjust HV-AC, you will see the particles become more tightly trapped when HV-AC is higher.

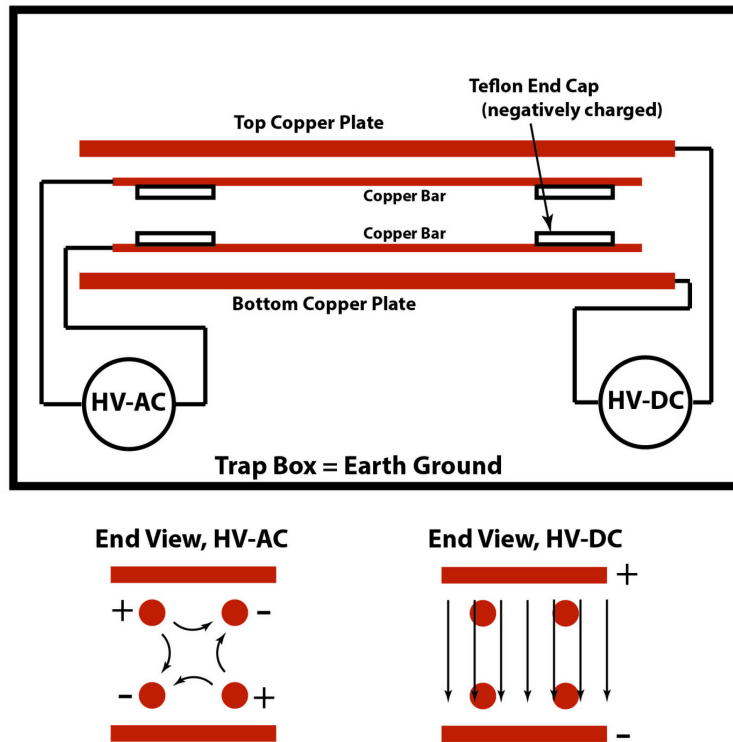

Figure 9. A schematic diagram of the Linear Trap Box. Four copper bars form the electrodes for a 2D quadrupole trap, as seen in the HV-AC end view. Note there is no trapping along the trap axis. Two copper plates are used to apply a static electric field, as shown in the HV-DC end view. The Teflon end caps provide weak static fields that keep negatively charged particles from leaking out the ends of the trap.

- You will also see some of the particles go a bit crazy at high HV-AC. In our calculations above we assumed that the micromotion was small, as this made the equations simpler. In reality this is not always a good assumption. When the micromotion became high, the trapping becomes unstable, causing particles to go into larger orbits. If you look in from about 45 degrees, from one end of the front opening, you may be able to see these diamond-shaped orbits. These orbits result from a *dynamical instability* in the quiescent trapping behavior. It's complicated, so we will not discuss it here, but this unstable behavior is critical for making ion mass analyzers, as was mentioned in the introduction above. As with many things in physics, the more deeply you delve into it, the more interesting it becomes.
- Next turn up HV-AC to 6 kV and load a large number of particles into the trap. You should witness a phenomenon we like to call the *trapnado*. As far as we can make out (the phenomenon has not been studied much so far), each orbiting particle acts a bit like a tiny fan that blows air outward, creating a slight low-pressure region at the center of the orbit. With many particles rotating together, the low pressure draws more particles in along the trap axis. This positive feedback results in a knot of particles rotating around the trap axis. The air currents counter the electric fields that would normally cause the particles to repel one another. This is a many-particle collective effect that is somewhat unique to linear traps operating in air, and no full explanation of this phenomenon exists. If you turn HV-AC back down, you will see the trapnado disperse back into a quiescent collection of individual particles again. Take a picture or two of the trapnado for posterity.
- You can see the trapnado rotation if you strobe the laser. You will have to open up the lens aperture and use a slow shutter speed to see this clearly on the camera. You can keep the trapnado centered in the camera by moving the Teflon end caps closer to the center of the trap. If your eyesight is good, you can also see the trapnado rotation directly from a 45-degree angle, through one side of the front opening.

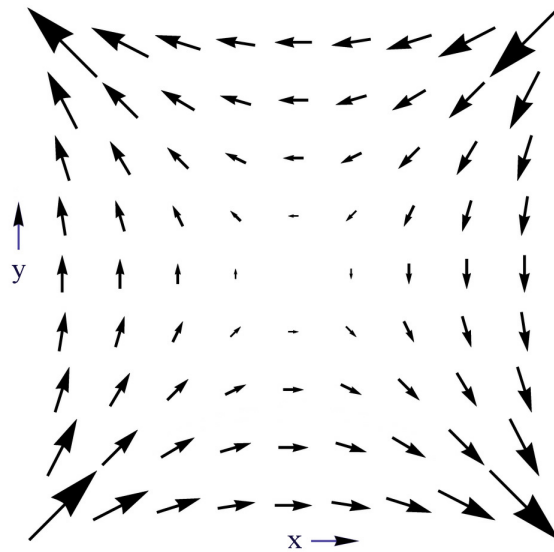

Figure 10. A vector plot of the electric fields near the center of the Linear Trap, as a function of x and y . This geometry produces little electric field along the horizontal axis of the trap (here given by the z direction coming out of the page).

- Next go back to lower values of HV-AC and make a simple linear collection of ions. Adjust HV-DC to balance gravity, then turn down HV-AC to remove particles from the trap. In this way you can select particles that have similar values of q/m . If you turn HV-AC up a bit, you should be able to observe a nice set of ions trapped on a line. This is basically a one-dimensional Coulomb crystal. The particles are pushed inward slightly by the Teflon end caps, but at the same time they have like charges and repel one another. Take a photo here also.

4 Lab Procedures – Week Two

4.1 The Single Particle Trap

The Single Particle Trap (SPT), as the name implies, is designed to allow you to examine and observe the properties of a single trapped ion. A schematic drawing of the SPT is shown in Figure 11.

- If the SPT Box is not set up on the chassis, ask your TA for help doing this. Also make sure nothing is connected to either the Laser Strobe IN or the LED Strobe IN ports at this time.
- If you look through the top slot in the Trap Box, and turn the LED Brightness knob all the way up, then you can see the different electrodes in the trap that are shown in Figure 11. The metal trap parts inside the Trap Box have high voltages on them, so again do not touch with your fingers or with any metal objects.
- The SPT includes a built-in microscope objective, and you can see this sticking out of the back of the Trap Box. Light from this objective goes through a folding mirror (a prism in this case), through a couple of telescoping tubes (to keep the room lights out), and onto the camera sensor. There is no longer a lens attached to the camera. Again you focus by moving the camera back and forth on its rail.
- The next step is to check out the lighting. If you look at the TV screen you should see a bright disk, which is the image seen through the microscope. Turn the LED Brightness down so the light doesn't saturate the camera sensor. If the disk is not centered on the TV, you can adjust the image up or down by rotating the prism. There is a set-screw on top of the prism assembly to fix this rotation (ask your TA for help if this is not clear). It is also possible to move the image left or right on the TV, but this is usual okay without additional adjustments. If not,

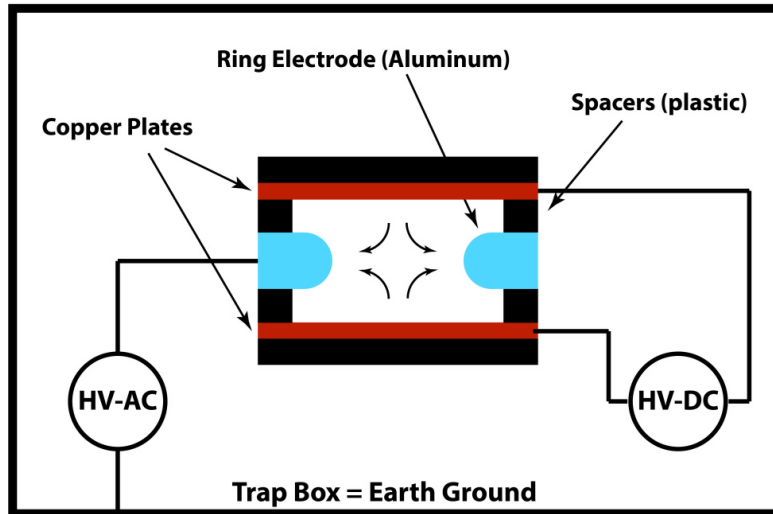

Figure 11. A schematic diagram of the Single Particle Trap Box. The ring electrode is a square plate with a round hole in the center. Not shown are four small horizontal holes in the Ring Electrode, for illuminating and viewing trapped particles.

ask your TA for assistance.

- The Strobe IN ports can be used to turn either the laser or the LED off, and generally you will only want one on at a time. Connect a BNC Ground to either port to turn these off. Check that both turn off when you do this.
- Next turn off the LED while leaving the laser on. Make sure the laser beam goes into one side of the Trap Box, and that you see some light coming out the other side. If not, align the laser to make this happen. You should see a diffuse green halo on the TV. If not, try using a longer shutter speed. The green glow is just a bit of scattered laser light. Now you are ready to load the trap.
- To load some particles, turn the HV-DC down to zero and turn the HV-AC up to 4 kV. Use the Teflon wand with the small, pointed tip to load some Lycopodium spores into the trap. As before, charge the tip of the wand by rubbing it with a cloth, pick up some spores, and drop them through the small hole in the top of the trap. You may have to poke the tip of the wand right into the hole. Do not dump a lot of dust into the trap; a small dab on the tip of the wand should be plenty. When particles load, you will see some laser streaks on the TV. If this does not work after a few attempts, ask your TA for assistance.
- When you see some particles on the TV, adjust the HV-DC and HV-AC knobs to see what happens. As before, the HV-DC will move the particle vertically as it counters gravity, and you will see a laser streak for each particle that outlines its micromotion. The HV-AC knob changes the trapping force, so higher HV-AC will pull the particles closer to the trap center. As before, if you turn the HV-AC knob up high, you may see the particle motion go unstable. This may not happen with all particles.
- Next adjust HV-DC so one of the particles is near the trap center, and then turn the HV-AC knob down and up quickly to isolate a single particle. This may take a few attempts, but you should be able to load a single particle into the trap.
- With a single particle in the trap, set the HV-AC knob back to 2 kV, and then adjust HV-DC to balance gravity and bring the particle to rest at the center of the trap. When you accomplish this, the particle will appear as a small, bright green dot on the TV screen. If HV-DC cannot go high enough to balance gravity, then your particle does not have enough charge; try again, and rub the tip of the wand quite a bit, so it becomes more highly charged. (How easy this is may depend on the humidity, which can vary from day to day.) Sometimes you will see two dots, indicating two particles stuck together. If that happens, load a new particle and try again. Once you have a single trapped particle, put a cover over the top of the trap to reduce air currents, and the particle will sit at the center of the trap indefinitely.

- Laser light, as it turns out, is not especially good for imaging objects. Light scattering off different parts of the surface creates interference patterns called laser *speckle* (you can look that up online if you want to learn more about it). These interference patterns tend to degrade images of objects – the effect is not terrible, but it does reduce the image quality. To get around this, turn off the laser (using the BNC Ground) and turn on the LED. You should see a bright disk with a dark particle in the middle. If you adjust HV-DC, you will see that the micromotion causes the particle to become something of a blur on the TV. Adjust HV-DC to balance gravity and the blur turns into a fairly clear view of a stationary particle at the center of the trap.
- Next you can use these observations to measure the charge-to-mass ratio of your trapped particle. Use the measure function on your oscilloscope, or a voltmeter, to measure the HV-DC Monitor signal V_{mon} . Adjust the HV-DC knob to zero out the particle motion, which is where the DC electric force just balances gravity; call this setting $V_{mon,0}$. If you change the HV-DC knob and zero out the motion a half-dozen times, then each time you will get a slightly different value for $V_{mon,0}$, and this will give some idea how well you are measuring this quantity. As you can see, the main source of uncertainty in measuring $V_{mon,0}$ is knowing exactly when the micromotion goes to zero on the TV screen. From the scatter in your numbers, produce a measurement of $V_{mon,0}$ with a realistic error bar (you can google “standard-deviation calculator” to do the calculation from your data). You should be able to measure $V_{mon,0}$ to an uncertainty of perhaps one percent or better if you are careful.
- The DC voltage applied between the top and bottom plates of the trap (see Figure 11) is equal to $V_{DC} = 82 \cdot (V_{mon} - 0.06\text{volts})$, and the DC electric field at the trap center is $E_{DC} = 4850 \cdot (V_{mon} - 0.06\text{volts})$ volts/meter.
- Once you know the DC electric field that balances gravity, $E_{DC,0}$, you can calculate the particle’s charge-to-mass ratio. When the DC electrical force exactly cancels gravity, we can write $qE_{DC,0} = mg$, so the particle charge-to-mass ratio is simply

$$\frac{q}{m} = \frac{g}{E_{DC,0}}$$

Assuming d and the voltage calibration are known to high accuracy, turn your measurement of $V_{mon,0}$ into a measurement of q/m with an error bar (in SI units, of course).

- The next step is to measure the particle size as best you can, use that measurement to estimate the particle mass m , and from that estimate the charge q on your particle. With the particle at rest as best you can, use a plastic ruler to measure the particle diameter on the TV image. You will see that the particle is not quite round, so measure several diameters to get some average. And yes, the particle is small, so you will not end up with a terribly accurate measurement. That’s okay; the uncertainty should be reflected in your error bar for the diameter. (Remember that at this point you have absolutely no idea how much charge is on this particle. You perhaps could not even guess to better than a factor of 1000. With that in mind, even measuring q to a factor of two provides a huge reduction in your ignorance!)
- Once you have measured the particle diameter on the TV screen, you need to calibrate this measurement. For this we have a calibration wand, which is a plastic stick with a small metal rod at the end. The rod has been measured to be 1.23 mm in diameter. Turn HV-AC and HV-DC down to zero and insert the wand through the top hole in the trap. Hold the rod stationary and in focus while you measure its diameter on the TV screen, again using your plastic ruler. From this you can produce a measurement of the magnification factor on the TV, and from that you can produce a measurement of the diameter of your trapped particle (with an error bar, of course).
- From the diameter you can calculate the particle volume, and you can propagate the error bar using the derivative of the volume formula, which can be written

$$\frac{dV}{V} = 3 \frac{dR}{R}$$

where R is the radius. We have separately measured the particle density to be $510 \pm 40 \text{ kg/m}^3$, and from all that you can produce a measurement of m . Combining this with q/m gives q . Record all these measurements (with error estimates) in your notebook.

- At this point you should pause and think about what small forces you have been measuring. If you measured $V_{mon,0}$ to an accuracy of 1 percent accuracy, then you are able to see changes in external forces that are about $mg/100$. Calculate this force and express your answer in picoNewtons. This is the limit of how small an external force you could detect on a trapped particle. Now a really expensive laboratory scale might measure down to one microgram (A nickel weighs five grams, so a microgram is pretty small). What is mg in picoNewtons when m is

one microgram? How much smaller were the forces you just measured in the SPT?

If you were to spend many afternoons with the SPT instead of just one, then you could develop a full mathematical model of the particle dynamics inside the trap. You could measure the particle displacement and the amplitude of the micromotion as a function of E_{DC} , using these to quantify the model. You could explore the particle instabilities as well, using Mathematica to numerically solve the equation of motion directly. Scientists have been exploring the properties of Paul traps for many decades, and have developed many useful experimental tools in the process. Many aspects of the many-particle behaviors, such as the trapnado, are actually not well understood even now. One purpose of this lab was to give you a sample of laboratory exploration and of how one begins making precise mathematical models of natural phenomena, which is really the essence of what physicists do.